

IEC LV Motors		Technical Data Sheet				
Project		Location				
Department/Author		Customer name		Customer ref	Item name	
Our ref.		Rev/Changed by	Date of issue	Saving ident	Pages	
		A	6/12/2025	untitled (1).xslm	1.00004 1(3)	
No.	Definition	Data	Unit	Remarks		
1	Product	<b>TEFC, 3-phase, squirrel cage induction motor</b>				
2	Product code	<b>3GBA 251 210-ADDIN</b>			Calc. ref. 3GZH021025-49	
3	Type/Frame	<b>M2BAX 250SMA 2</b>				
4	Mounting	<b>IM1001, B3(foot)</b>				
5	Rated output P <sub>N</sub>	<b>55</b>	kW			
6	Service factor	<b>1</b>				
7	Type of duty	<b>S1 100%</b>				
8	Rated voltage U <sub>N</sub>	<b>415</b>	VD	+10, -10 %		
9	Rated frequency f <sub>N</sub>	<b>50</b>	Hz	+5, -5 %		
10	Rated speed n <sub>N</sub>	<b>2970</b>	r/min			
11	Rated current I <sub>N</sub>	<b>94.9</b>	A			
12						
13	Starting current I <sub>s</sub> /I <sub>N</sub>	<b>7.7</b>				
14	Nominal torque T <sub>N</sub>	<b>177</b>	Nm			
15	Locked rotor torque T <sub>s</sub> /T <sub>N</sub>	<b>2.5</b>				
16	Maximum torque T <sub>max</sub> /T <sub>N</sub>	<b>3.4</b>				
17						
18						
Load characteristics		Load %	Current A	Efficiency %	Power factor	
19	PLL determined from residual loss	100	94.9	94.3 / IE3	0.85	
20		75	75.2	94.2	0.81	
21		50	57	93.3	0.72	
22						
23	Thermal withstand time hot	<b>11</b>	s			
24	Thermal withstand time cold	<b>22</b>	s			
25	Insulation class / Temperature class	<b>F / B</b>				
26	Ambient temperature	<b>55</b>	°C			
27	Altitude	<b>1000</b>	m.a.s.l.			
28	Degree of protection	<b>IP55</b>				
29	Cooling system	<b>IC411</b>				
30	Bearing DE/NDE	<b>6315-2Z/C3 - 6212-2Z/C3</b>				
31	Sound pressure level (LP dB(A) 1m)	<b>74</b>	dB(A)	at no-load		
32	Moment of inertia J = ¼ GD2	<b>0.426</b>	kg-m2			
33	Position of terminal box	<b>Top</b>				
34	Direction of rotation	<b>Bi-directional</b>				
35	Weight of rotor	<b>84</b>	kg			
36	Total weight of motor	<b>344</b>	kg			
37	Paint shade	<b>Munsell Blue</b>				
38	Cable size	<b>2R x 3C x 120 sq.mm. (2nos. * M50)</b>				
39	Vibration	<b>As Per IS 12075</b>				
40						
41						
42	Method of Starting	<b>VFD</b>				
43	Efficiency level IE3 are at Sinusoidal supply					
44	Temperature rise is limited to Class B upto 40.7kW					
45	Speed range 30% to 100%					
46						
47						
48						
<b>Specialties</b>						
49	CE Marking					
50	55deg Ambient					
51	Space heater, PTC 3nos.					
52	SS Nameplate, SS Hardware					
53	VPI Treated					
54	Jacking bolt provision					
Remarks:						
Applicable standards: IS 12615:2018, IEC 60034-30-1:2014						

All performance values are subject to IS/IEC tolerances

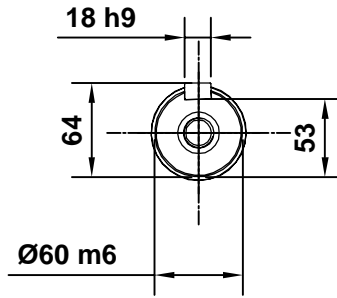

Terminal box for Acc.

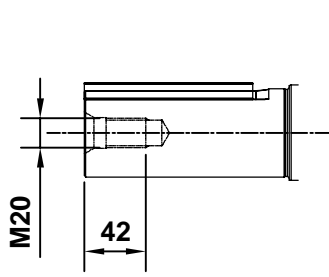
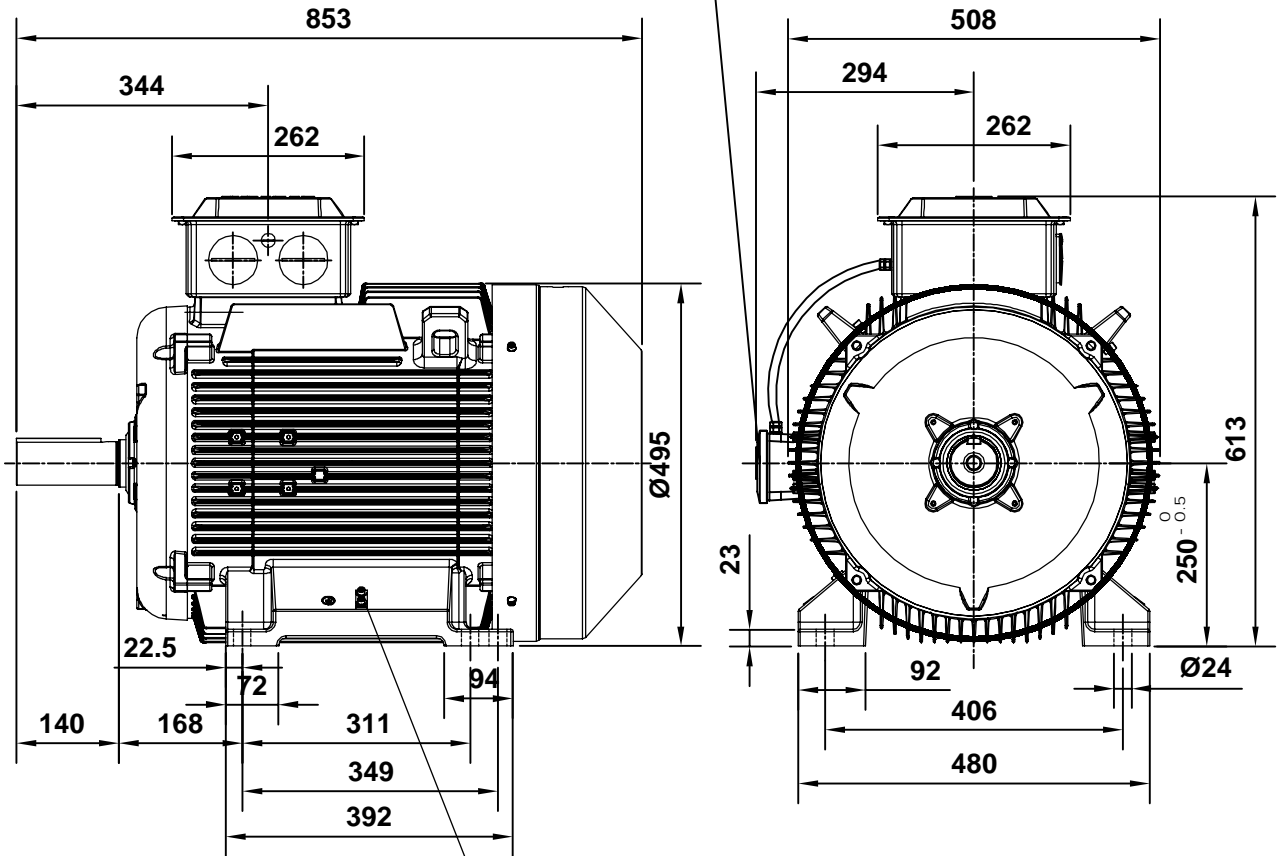

2nosxM6 earthing screws

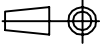
<b>Motor Dimension Print</b>	Motor Type : <b>M2BAX250SM 2P (IE3)</b>	Document Nº : <b>3GZH500025-53</b>
Description : <b>Motor IE3 foot mounted IM1001 (Separate box for accessories)</b>		
Unit : <b>ABB, LV Motors, India</b> Date : <b>2016-06-27</b>	Issued by : <b>DANISH</b> Approved by : <b>DKS</b>	Replaces : Replaced by :
<b>ABB India Ltd.</b>	Customer Reference :	